

Kodar Energomontaža d.o.o.
2025 ESG REPORT

Belgrade March 2026

CONTENTS

03

Introduction

04

About the company

06

ESG impact

08

Materiality assessment

10

Building a greener future

17

Building a safer future

24

Building a responsible future

29

GRI Index



INTRODUCTION

Our annual Sustainability Report is prepared in accordance with the principles of transparency and accuracy. It highlights the issues most relevant to our business and stakeholders, with a focus on energy transition, environmental protection, employee health and safety, our broader societal role, and business governance.

This report has been prepared with reference to the principles of the Global Reporting Initiative (GRI).

This non-financial Report represents the first consolidated sustainability report of the Kodar Group. This report includes subsidiaries that are registered and operate in Serbia, covering approximately 95% of the Group's total revenue. As inclusion of 100% of subsidiaries requires additional resources, we plan to expand the scope to include all Group members in the next reporting periods to allow for broader coverage.

For any questions regarding this report or its contents, please contact:

Zoja Milovančević

ESG Coordinator

mob: +381 64 826 2161

e-mail: zoja.milovancevic@kodar.rs



ABOUT THE COMPANY

Kodar Energomontaža, founded in 1958, is one of the leading EPC (Engineering, Procurement, and Construction) companies in Southeast Europe, with more than six decades of experience in the fields of energy and telecommunications.

With headquarters in Serbia and a strong network of subsidiaries in Montenegro, North Macedonia, and Croatia, we have delivered projects across Europe, including Scandinavia, as well as in West Africa.

Our activities cover the full EPC cycle, from engineering and procurement to construction and ongoing maintenance. We provide a full scope of EPC services, from design and engineering to construction and long-term maintenance. Our driving force is building energy paths from source to end users.

In addition to decades of experience in conventional energy and infrastructure, we have in recent years expanded our activities in renewable energy, actively contributing to the energy transition. Our development portfolio includes solar power plants, wind farms, and hybrid energy systems, supporting the shift toward low-carbon energy in both regional and international markets.

We continue to strengthen transmission lines, substations, and electrical systems, ensuring a stable and secure energy supply for national grids and local communities.

Through these activities, we contribute to the development and modernization of critical infrastructure while responding to the evolving needs of the energy sector.

As a company whose growth is grounded in the principles of responsibility and sustainability, we have embedded these values into the very core of our business. They are reflected in our vision, mission, and everyday actions, ensuring that everything the company builds contributes to a more sustainable and resilient future.

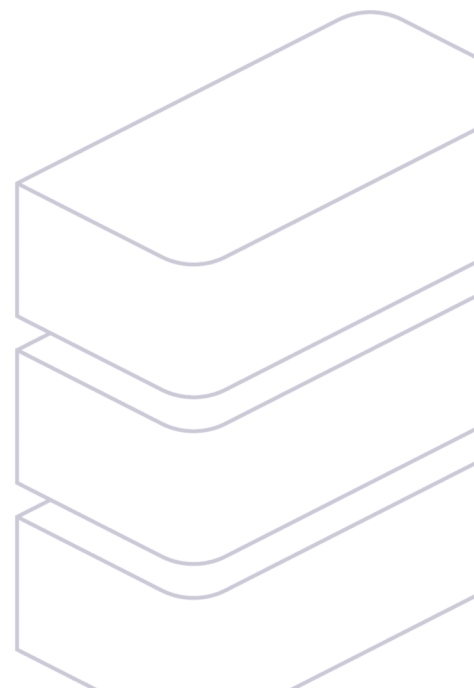

ABOUT THE COMPANY

OUR MISSION

Using our knowledge and experience, we create innovative and sustainable structures that enable better living conditions.

OUR VISION

Kodar exists to create great structures.

OUR VALUES

Inventiveness: We don't settle for the ordinary – with knowledge, experience and a fresh perspective, we create solutions that make a difference and build exceptional structures.

Teamwork: We believe great structures are built on honesty, trust and the expertise of a team that pushes the boundaries together.

Responsibility: Creating great structures means being accountable – to our colleagues, partners and the communities we belong to.

Knowledge: Knowledge is the foundation of everything we do – we learn, share experiences and grow in order to build outstanding structures.



ESG IMPACT

Our approach to sustainability

The energy sector is under growing pressure. Climate change, resource constraints, and stricter policies are reshaping how projects are designed, built, and maintained. At the same time, investors, regulators, and local communities expect greater accountability. Serbia's ongoing transition toward a low-carbon economy and the national goals for renewable energy expansion create both opportunities and responsibilities for companies like ours.

We respond to these changes by complying with regulations and managing potential risks. In doing so, we protect our reputation and maintain access to international markets.

Sustainability in practice means clear priorities that align our operations with applicable regulations and recognized industry standards, while continuously seeking ways to improve operational efficiency and reduce environmental impact.

We invest in renewable energy facilities, including solar, wind, and hybrid systems, and continue to modernize transmission lines and substations to strengthen energy security. Occupational health and safety remain our constant focus, as do innovation and responsible resource management throughout every phase of the EPC cycle.

These principles extend across our value chain. Partnering with responsible suppliers helps us mitigate risks, promote consistent quality, and build trust with clients, investors, and communities. In this way, sustainability is integrated directly into our everyday operations.

Our work is designed to endure, carrying a responsibility that extends beyond construction itself. To guide our sustainability efforts, we have established three thematic pillars that reflect our strategic priorities. These pillars define the areas where we can create the greatest long-term value and ensure that our growth is consistently aligned with responsible business practices.

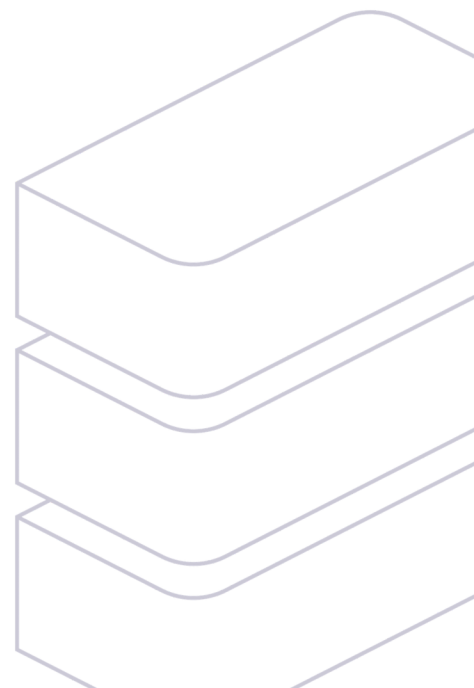

07

OUR STRATEGIC PILLARS

To better capture the topics outlined above, we have shaped a clear sustainability strategy built around three main pillars. They form the foundation of our approach and help us stay focused on the areas where we can make the greatest impact.

Each pillar is supported by clearly defined targets and measurable commitments that enable us to track progress and maintain transparency in reporting:

BUILDING A GREENER FUTURE



Targets

- Achieve net-zero emissions by 2050.
- Reduce Scope 1 and Scope 2 emissions by 10% by 2030 (compared to 2025).
- Reach 100% renewable electricity consumption by 2030.
- Scale renewable energy assets to 439.8 MW by 2030 from solar and/or wind.
- Increase the share of revenue from green projects* to 60% by 2030.

BUILDING A SAFER FUTURE



Targets

- Ensure women hold 30% of leadership positions.
- Maintain the gender pay gap within $\pm 3\%$.
- Maintain zero fatalities.
- Reduce the number of workplace injuries and resulting lost time incidents (LTIFR) by 20% compared to 2025.

BUILDING A RESPONSIBLE FUTURE



Targets

- Maintain zero regulatory non-compliance incidents.
- Ensure 100% of senior management board members complete annual anti-corruption training.
- Include ESG clauses in 100% of contracts with suppliers and subcontractors** by 2028.
- Integrate ESG data insights into 100% of procurement decisions for suppliers and subcontractors** by 2027.

* Revenue generated from renewable energy-related projects

** Suppliers with annual procurement above EUR 100k and subcontractors with fees exceeding 10% of the project value.

08

MATERIALITY ASSESSMENT

Materiality plays a significant role in defining how sustainability is addressed within our company. As such, we aim to integrate economic, environmental, and social considerations into decision-making processes and align our business objectives with the expectations of stakeholders.

As part of our ongoing commitment to enhancing sustainability management and reporting, we carried out a materiality assessment to identify and prioritize the ESG topics most relevant to our operations. This process involved evaluating how our activities impact both society and the environment, with topics deemed material if they represent significant environmental or social effects connected to our business. The insights gained from this assessment form the foundation for setting clear ESG priorities and strengthening the quality and focus of our future reporting.

To define the scope and focus areas, we carried out an internal review and mapped our main business activities and our value chain to pinpoint where our operations have the most significant environmental and social impacts. In addition to internal expertise, the process was supported by a peer review of sustainability practices within the EPC and infrastructure sectors, as well as reference to relevant sector standards. Key functions, including our ESG team, participated in approving the material topics that are most relevant to our business model.

The preliminary results of the assessment were reviewed by management through internal ESG workshops, after which the findings were formally validated and approved by the highest governance body of the company.

We are also committed to contributing to the United Nations Sustainable Development Goals (SDGs) as part of our broader sustainability agenda. We recognize the importance of these goals in addressing key environmental, social, and governance challenges, and we have identified the areas where we can create the greatest impact.



MATERIAL TOPICS

Figures 1 and 2 below outline the material topics and the relevant Sustainable Development Goals (SDGs) that we support through our core business activities and strategic initiatives.

Figure 1 - Material Topics



Figure 2 - Relevant UN Sustainable Development Goals (SDGs)



BUILDING A GREENER FUTURE

GHG emissions

Aware of the impact our operations can have on the environment, we have committed to reducing GHG emissions from our operations by 10% by 2030 (using 2025 as a baseline) and are on the path to achieving net-zero by 2050. To support this commitment, we systematically monitor and calculate our greenhouse gas (GHG) emissions, following the recommendations set out in the GHG Protocol. We began by assessing and tracking our Scope 1 and 2 emissions during 2023 and 2024, with the aim of enhancing our calculations in the following period, including Scope 3 emissions.

Scope 1 emissions are calculated based on the total fuel consumption for each type of fuel used (gas, petrol, diesel, etc.). Scope 2 emissions are calculated using electricity consumption data and national emission factors, as well as heating consumption.

In 2023, our Scope 1 emissions amounted to 944.1 tCO₂e, while Scope 2 emissions amounted to 327.1 tCO₂e. Due to higher business activity and increased machinery use, both Scope 1 and Scope 2 emissions were higher compared to the previous year. In 2024, Scope 1 emissions amounted to 1,433.3 tCO₂e, and Scope 2 emissions reached 340.1 tCO₂e.

In 2025, our Scope 1 emissions were lower, amounting to 1,306.26 tCO₂e. Scope 2 emissions in 2025 were significantly reduced, amounting to 99.21 tCO₂e.

The results of our GHG calculations provided a clear understanding of the main sources of emissions, enabling us to define concrete actions and initiatives to achieve the goals we have set.

To reduce Scope 1 emissions, we plan to gradually replace passenger and freight vehicles with new models that comply with European Union environmental standards (Euro 6). Furthermore, we intend to maintain a direct supplier-to-site delivery system to optimize logistics, reduce unnecessary transportation steps, and minimize related emissions.

As part of our commitment to reducing Scope 2 emissions, we increased the share of electricity sourced from renewable energy, with our headquarters powered by 90% renewable electricity, supplied by our affiliated company and backed by guarantees of origin. The goal is to reach 100% electricity consumption from renewable sources, fully supported by guarantees of origin.

Figure 3 - Scope 1 and 2 annual emissions (tCO₂)

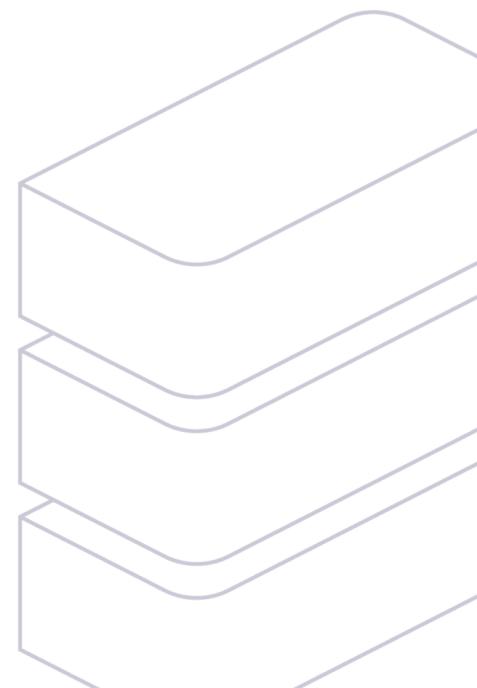
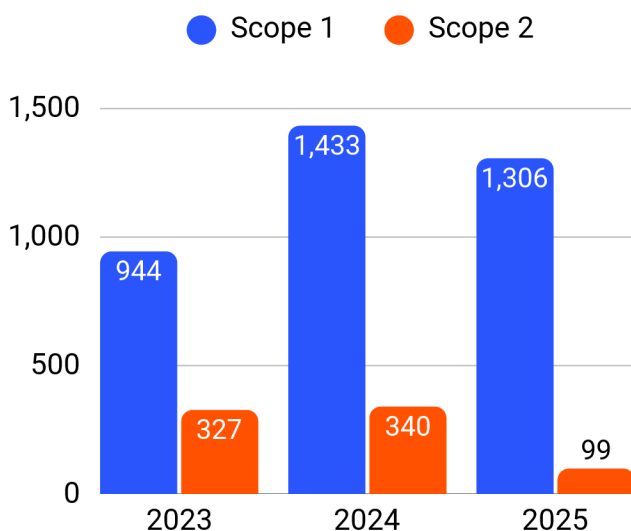

BUILDING A GREENER FUTURE

Energy management

Our commitment to renewable energy production is a central element of our business strategy, reflecting our dedication to aligning with evolving climate policies and capitalizing on emerging market opportunities. We prioritize the development and construction of solar and wind energy projects to support long-term growth while simultaneously aiding the transition to a low-carbon economy. Through these efforts, we seek to contribute meaningfully to sustainable development and enhance our strategic position within the energy sector.

Serbia's transition to a low-carbon economy, driven by its national climate commitments, further validates our strategic direction. The country's coal phase-out plans and greenhouse gas reduction targets are accelerating renewable energy investments. Our focus on renewable energy production aligns with these priorities and supports our long-term goal to scale up renewable energy assets to a total installed capacity of 439.8 MW from solar and wind sources.

In support of our long-term renewable energy goal, we are planning to develop two major projects: the Jasikovo wind farm, and the Brebex solar power plant. Both are managed through separate SPVs (Special Purpose Vehicles) within the company, and together drive the shift toward low-carbon energy in Serbia.

Figure 4 - The Brebex Solar Power Plant Specifications

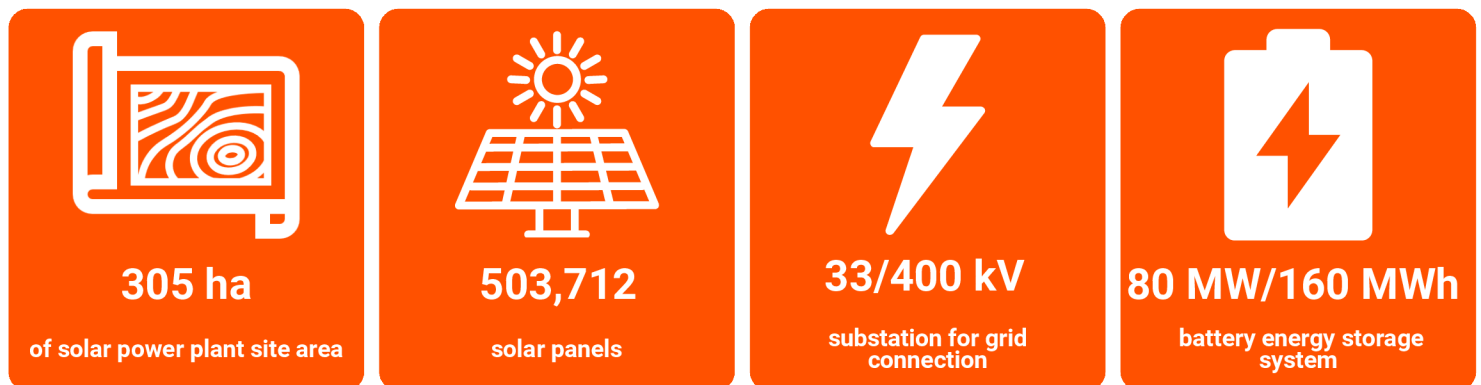

The Brebex Solar Power Plant (300 MW) is situated in southeastern Serbia, within the municipality of Dimitrovgrad, spanning approximately 305 hectares. The project will consist of approximately 37,150 solar panels, including photovoltaic panels, inverters, and internal medium-voltage infrastructure 0.8/33 kV connected to a 33/400 kV substation. It will also include an 80 MW/160 MWh battery energy storage system to enhance grid stability and energy availability. Shared road infrastructure and common facilities will support both projects, ensuring operational efficiency and reinforcing our commitment to advancing Serbia's renewable energy sector.

BUILDING A GREENER FUTURE

Figure 5 - The Jasikovo Wind Farm Specifications

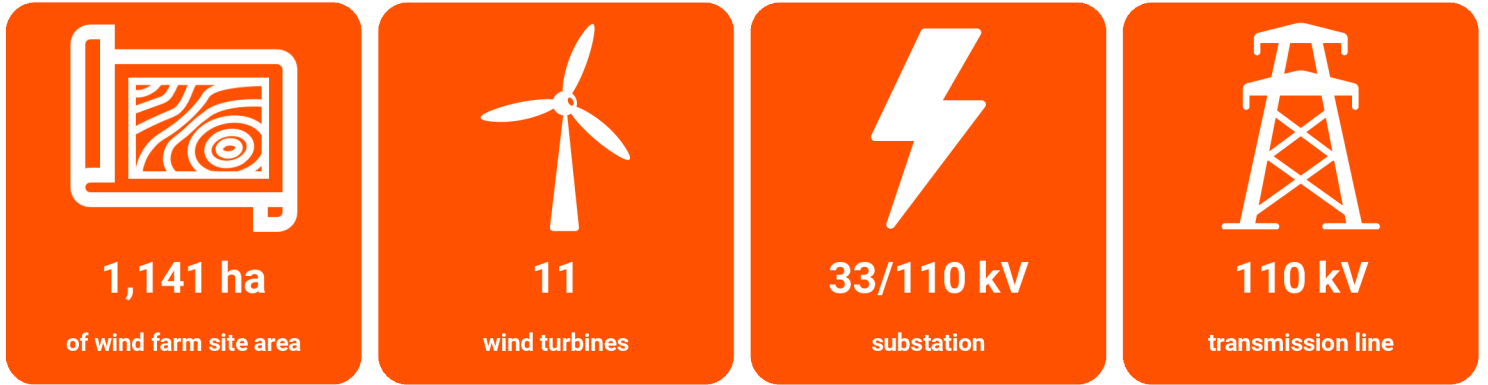

The Jasikovo wind farm (70 MW) is located in northeastern Serbia, across the municipalities of Žagubica and Majdanpek, covering an area of 1,141 hectares. The project includes the installation of 11 wind turbines with dedicated construction pads, a 33/110 kV substation, and a 110 kV overhead transmission line, as well as an internal network of access roads.

Energy consumption

To support our Scope 2 reduction goals, we systematically monitor energy consumption within our operations. This approach enables us to identify areas for improvement and track progress toward greater energy efficiency.

In line with our broader decarbonization efforts, the company is actively optimizing its energy consumption profile by increasing the share of renewable energy sources and improving overall energy efficiency. In parallel, we have implemented key efficiency measures across our operations, including the installation of LED lighting systems and heat pumps, contributing to reduced energy use and a lower environmental impact. The table below provides an overview of our energy consumption by source for 2023, 2024 and 2025.

Table 1 - Energy consumption by source for 2023, 2024 and 2025.

	2023	2024	2025
Total workspace area (m²)	3,124	3,124	3,124
Total fuel consumption (l), of which:	348,377	514,986	501,194
-Diesel	340,491	508,523	451,503
-Gasoline	6,547	6,426	49,691
-Gas	154	36	0
Electricity consumption (kWh)	367,652	383,333	363,156
Energy consumption - district heating (kWh)	66,987	68,307	84,854

BUILDING A GREENER FUTURE

Waste management

As a company aware of the importance of sustainability, we strive to operate in line with these principles. Our goal is to use resources efficiently, minimize the amount of waste generated, and ensure that any waste produced is managed responsibly and in an environmentally sound manner. In doing so, we aim to safeguard the health of our employees as well as the communities in which we operate. The seriousness of our commitment to this issue is further demonstrated by our ISO 14001 certification.

In conjunction with the above practices, we seek to ensure compliance with the EU Waste Framework Directive. The waste management hierarchy, as defined by law, establishes the order of priorities in sustainable waste management. We follow this principle by first focusing on the prevention and reduction of waste generation through the efficient use of resources and cleaner technologies, where economically justified. When waste is produced, we ensure its proper collection and sorting, prioritize reuse and recycling, and promote recovery processes such as composting or energy recovery.

Only when no other viable solution exists do we proceed with the safe and controlled disposal of residual waste. At sites under our full management, where Kodar bears complete responsibility for waste management, a specific Waste Management Plan is prepared for each location.

All waste is classified into hazardous and non-hazardous categories. Non-hazardous waste mainly arises from the disposal of packaging, construction materials, and other by-products of day-to-day business activities.

The total amount of non-hazardous waste generated and recycled increased from 5.98 tonnes in 2023 to 11.97 tonnes in 2024. In 2025, 4.21 tonnes of non-hazardous waste were generated.

In addition to non-hazardous waste, hazardous waste was also generated during the reporting year, such as used printer cartridges and discarded electronic equipment. In 2024, we generated 0.635 tonnes of hazardous waste, while 1.7 tonnes were generated in 2025.

Figure 6 - Waste generated (t) by year

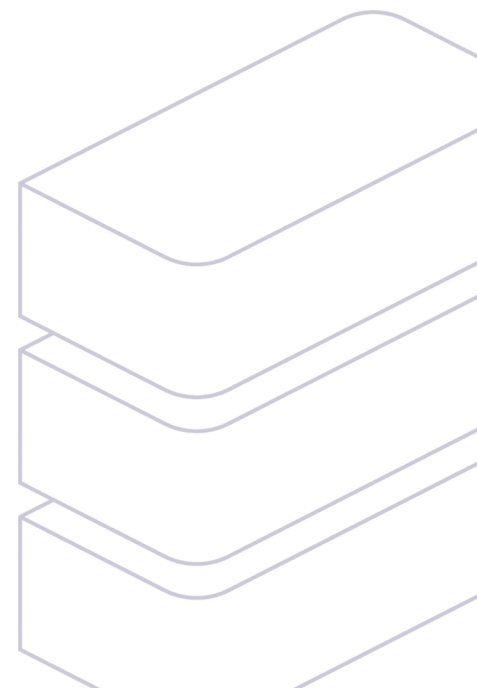
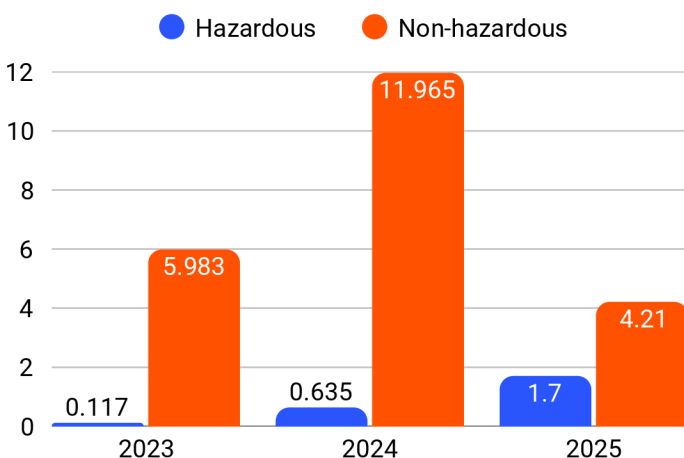

BUILDING A GREENER FUTURE

Waste management

To ensure that all waste is managed responsibly and safely, we cooperate with certified external partners who collect diverse types of waste, including paper, cardboard, metals, and electronic waste, and who ensure their further handling in compliance with regulations and best environmental practices. For every quantity of waste transferred, detailed documentation is maintained, ensuring transparency of the process and continuous monitoring of compliance with legal requirements. Additionally, within our office operations, Kodar implements responsible waste management measures through an internal Waste Management Plan, which includes waste separation, recycling, and raising employee awareness about the importance of responsible resource use.

Figure 7 provides an overview of the total amount and composition of waste generated in 2023, 2024 and 2025.

When we work on site as a subcontractor, waste management responsibilities lie with the main contractor, in accordance with contractual and regulatory requirements. Consequently, waste generated during such activities is managed and reported by the main contractor and is therefore not included in our company's waste data.

When performing work as a contractor for investors (such as transmission line construction), waste management is implemented in accordance with the site-specific Waste Management Plan established by the investor. The plan clearly allocates responsibility for different waste streams. Kodar manages all waste under its responsibility in full compliance with applicable regulations, using licensed waste management operators.

Figure 7 - Composition of waste (t) by year

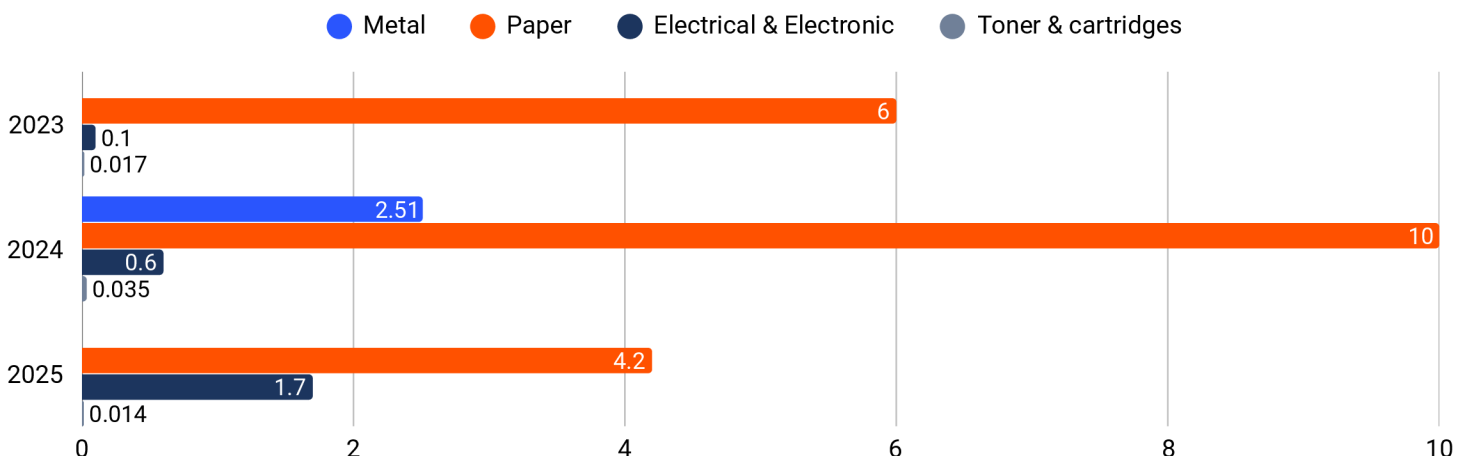

BUILDING A GREENER FUTURE

Ecological impacts of the Brebex project

To ensure that our projects do not adversely affect biodiversity or natural resource use, we conducted assessments of potential impacts on biodiversity for two key project locations situated in proximity to protected areas - the Brebex solar power plant in the municipality of Dimitrovgrad, and the Jasikovo wind farm located across the municipalities of Žagubica and Majdanpek. Environmental and Social Impact Assessment (ESIA) studies provide full transparency and are available for all stakeholders on the respective project websites.

The Brebex solar power plant (305 ha) is not located within a protected area, but it lies near the boundaries of the Gornji Visok and Vidlič Important Bird Area (IBA) and the Ecologically Important Area of Serbia's ecological network. According to environmental research, the area consists mainly of grassland, shrubland, and agricultural surfaces. Several species of conservation importance have been recorded at the site, including orchids, butterflies, birds, amphibians, and reptiles, which confirm the richness of the local biodiversity without indications of significant habitat disturbance or degradation.

We recognize that some construction activities may temporarily alter soil characteristics; therefore, after the project's operational life, our goal is to implement land rehabilitation and restore the area to its natural condition.

Brebex has a signed agreement with the Directorate for Agricultural Land for the lease of land intended for the construction of a solar power plant. According to this agreement, Brebex is required to prepare a land reclamation (rehabilitation) project.

Moreover, a land reclamation project was developed by an independent accredited third party, the Institute for Mining and Metallurgy Bor.

International regulations (EU Directives on Habitats, Birds, and Environmental Impact Assessment), domestic legislation, and conditions set by relevant public authorities, as well as international requirements and guidelines – such as those from the IUCN (International Union for Conservation of Nature) and the SNH (Scottish Natural Heritage) methodology – have been applied in the protection and restoration of habitats.

Impacts are limited to temporary construction activities, with no adverse effects expected during the operational phase. Based on the conducted analyses and monitoring, the Brebex solar power plant is considered environmentally acceptable, with no lasting impacts on biodiversity. The project supports the preservation of natural habitats in the surrounding area.

Figure 8 - Brebex Project Lifecycle



BUILDING A GREENER FUTURE

Ecological impacts of the Jasikovo project

The Jasikovo wind farm, covering an area of 1,141 hectares, is not situated within a protected area. It is located approximately 2.5 kilometers from the nearest protected zone and lies within a landscape predominantly composed of forest, shrubland, and grassland habitats.

Field surveys identified two strictly protected orchid species and two butterfly species, whose habitats were excluded from the project area through careful spatial planning, effectively preventing potential impacts on flora and fauna.

To further safeguard biodiversity, we conduct noise monitoring and apply a combination of environmental assessment methods that enable the implementation of mitigation measures to minimize or prevent risks. Minor and temporary impacts on air quality may occur during construction due to the use of construction machinery, but these effects are short-term and localized.

The direct impact on habitats, plants, and animal species is minimal, as those potentially affected habitats and plant species do not have significant conservation value.

However, certain bat species (five in total) do have conservation importance. Risk zones where these bats could be harmed have been identified, and post-construction monitoring will be conducted to assess the effectiveness of mitigation measures, which may include conditional shutdowns of wind turbines.

Expected impacts on biodiversity are limited, temporary, and reversible, with no significant changes to habitat structure or species populations anticipated during the operational phase. At the end of the project's life cycle, land restoration to its original state is planned, ensuring the long-term preservation of the area's natural values. Based on the conducted assessments, the project is considered environmentally acceptable, with no lasting impacts on nature or biodiversity.

To ensure effective environmental management for both Jasikovo and Brebex, we applied the principles of preventive planning and Good International Industry Practice (GIIP), accompanied by continuous environmental monitoring performed by an accredited organization.

Figure 9 - Jasikovo Wind Park distance to the nearest protected area



BUILDING A SAFER FUTURE

Human Rights and Community Relations

As a company engaged in the implementation of complex infrastructure projects, we recognize the importance of maintaining transparent and responsible relationships with local communities. Our approach to human rights and community relations is based on respect for people, cultural heritage, and the social and environmental context of each area in which we operate. In all our projects, we comply with the legislation of the Republic of Serbia and cooperate closely with relevant national and local institutions, while integrating good practices and European Union standards applied for similar activities.

In line with these principles, for every investment we conduct comprehensive Environmental and Social Impact Assessments (ESIA) to evaluate possible effects of our operations. Assessments include analyses of biodiversity, habitats, air, water, landscape, noise, cultural heritage, as well as the socio-economic conditions of local communities.

As part of this process, external consultants carry out biodiversity monitoring and archaeological field surveys. The results of these studies define mitigation measures and improvement actions, which ensure that our projects have minimal impact on the environment and the surrounding population.

Regarding activities that may have a current or potential negative impact on local communities, we conduct detailed assessments to identify and evaluate such effects for each project. Where impacts are considered more significant, appropriate mitigation and management measures are implemented in line with international standards and local regulations.

For the Brebex solar power plant, the study identified minor adverse impacts during the construction phase, primarily related to temporary traffic disruptions in the summer months and a limited visual impact of solar panels on nearby agricultural workers.

In the case of the Jasikovo wind farm, the key potential impacts include operational noise and visual effects. In accordance with international standards, mitigation measures are applied in response to noise-related complaints, including technical adjustments and sound insulation for affected households. Agreements were reached with 23 households to ensure fair compensation, property acquisition, or structural insulation. Visual impacts were assessed as moderate during construction and minor during the operational phase.

Figure 10 - Stakeholder Engagement Process



BUILDING A SAFER FUTURE

We actively follow the IFC Performance Standard (2012), which provides the framework for defining key stakeholders and communication methods through our **Stakeholder Engagement Plan**. We start by identifying all relevant stakeholders who may be affected by our projects or have an influence on their implementation. Based on this, we create a stakeholder list that outlines their main interests, expectations, and potential impacts. We then analyze their needs and level of involvement to define engagement objectives and the most appropriate communication approach.

Within each project, we also identify affected communities using an “impact zone map,” which helps us determine groups directly influenced by our activities. In the early stages of projects, we notify local authorities through a letter of intent and publicly present the key benefits for the community. For projects where we are the owner and investor, we develop a **Grievance Mechanism**, enabling all stakeholders to raise comments, suggestions, or concerns.

Through this approach, we aim to maintain a transparent and trust-based relationship with our stakeholders, ensuring continuous dialogue, accountability, and active participation across all our projects.

In addition to conducting our activities responsibly to avoid any negative impact on society, we actively contribute to the wellbeing of our communities through donations and support programs. Our contributions include support for children’s institutions, such as the Center for the Protection of Infants, Children and Youth - Zvečanska, as well as community events that celebrate local culture and heritage. These include traditional gatherings and festivals organized in the Homolje region, such as culinary and cultural events in Žagubica and Jasikovo, which promote local craftsmanship, preserve rural identity, and strengthen community engagement in the areas where we operate.

Figure 11 - Donations in 2024 and 2025 (RSD)

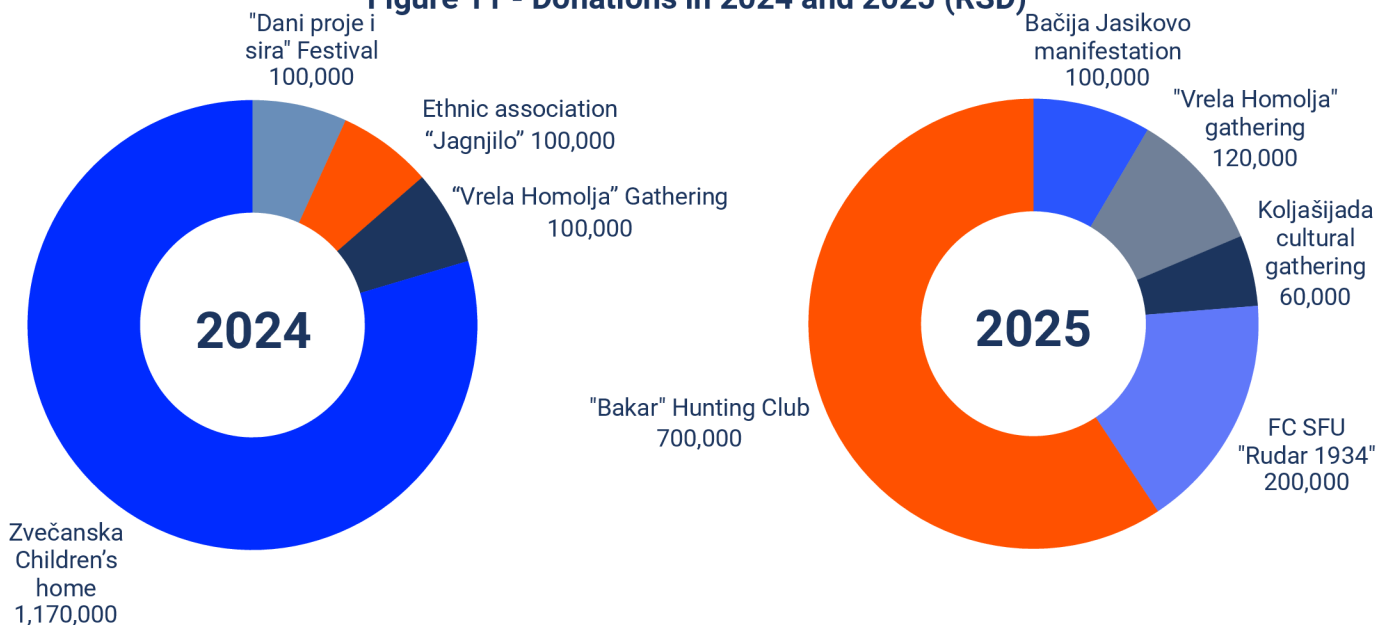

BUILDING A SAFER FUTURE

Employee Health and Safety

Our occupational health and safety (OHS) policies are aligned with the highest standards to ensure a safe and healthy working environment for all employees. Each employee has access to health and wellbeing services. In 2023, 2024 and 2025, all employees were covered by occupational health and safety measures. With this in mind, we continuously improve procedures and reduce risks across all processes, creating conditions for safe work and safeguarding employee wellbeing.

A licensed OHS team conducts risk assessments, while management is responsible for implementing the recommended measures. The **Risk Assessment Act** is revised every three years and is regularly updated whenever there are changes in processes, technologies, or job positions.

All workplaces and locations are included in the assessment. By applying the **Kinney method**, each potential hazard is evaluated according to probability, severity of consequences, and frequency of exposure. The combined result gives a risk index, which is classified into categories ranging from acceptable to extreme.

The analysis includes chemical, physical, mechanical, biological, and psycho-physiological factors, as well as organizational risks. Protective measures include proper use of PPE, machine safety solutions, noise and microclimate control, employee training, and ergonomic workplace design.

The outcome of each risk assessment is a set of measures designed to eliminate risks entirely or to reduce them to an acceptable level, supported by ongoing monitoring and continuous improvement.

In addition to technical and organizational measures, we put a strong emphasis on prevention through employee training. All employees undergo onboarding OHS training, while periodic and specialized training courses are organized according to job requirements. Safety induction and training are mandatory for all construction site workers and subcontractors, ensuring that every person entering the site is familiar with safety rules and emergency procedures. Procedures are included in the Kodar Rulebook on Rights, Obligations, and Responsibilities in OHS.

The most common training courses include evacuation and fire drills, ensuring that employees are prepared to act appropriately in emergency situations. Additional training is provided for specific roles, such as working at heights or proper use of PPE. In 2025, the company organized a total of **1,148 hours of OHS training**, up from 744 hours in 2024. Moreover, 150 employees were trained in first aid, rescue, and evacuation procedures and 12 fire drills were realized.

Figure 12 - Total employees trained in OHS

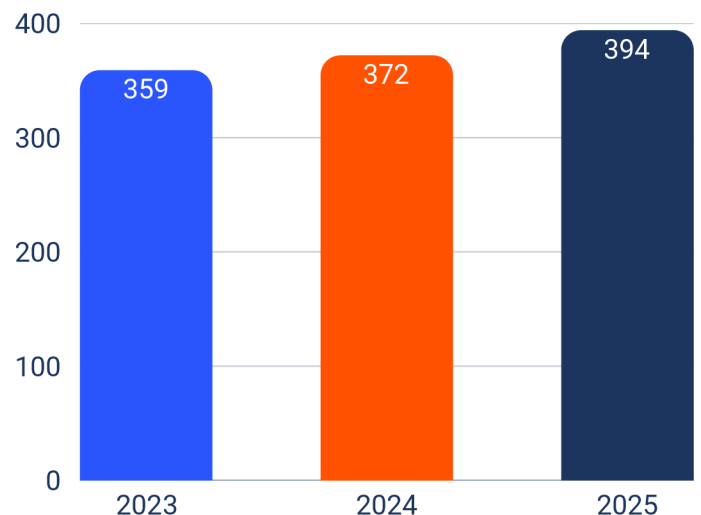

20

BUILDING A SAFER FUTURE

Employee Health and Safety

In our formally defined document “Regulation on Rights, Obligations, and Responsibilities in Occupational Health and Safety”, we have established a clear framework for ensuring the protection, wellbeing, and safety of all employees, contractors, and visitors. The framework defines the scope of duties, rights, and accountability across the organization.

The Employer provides and maintains safe working conditions, implementing preventive measures to manage occupational risks. The company ensures that all machinery, tools, and equipment are regularly inspected, maintained, and used in accordance with legal and technical requirements. Employees are provided with PPE, regular medical examinations, and ongoing safety training. All incidents, injuries, and occupational illnesses are recorded, investigated, and followed by corrective actions to prevent recurrence.

Employees are obligated to adhere to all prescribed safety rules and internal procedures, use PPE properly, and immediately report unsafe conditions, equipment malfunctions, or potential hazards to supervisors. Employees are also required to participate in scheduled OHS trainings and medical examinations, actively contributing to a culture of shared responsibility and safety awareness.

Supervisors and management ensure continuous enforcement of OHS standards across all operational units. Managers are accountable for ensuring that all workers receive safety orientation and understand their obligations. They monitor compliance, apply disciplinary measures if needed, and coordinate closely with the Committee.

The Occupational Health and Safety Committee plays a key role in evaluating risks, proposing improvements, and overseeing the implementation of safety measures. The Committee is composed of at least three employee representatives. The employer appoints at least one representative, ensuring that the number of employee representatives exceeds that of employer representatives.

Contractors and external partners are equally obliged to comply with our OHS rules. All contractors must demonstrate that their employees are properly insured and trained according to applicable regulations and that tasks are performed safely and responsibly.



BUILDING A SAFER FUTURE

Employee Health and Safety



Figure 13 - The OHS Committee functions

The Committee is responsible for monitoring all OHS matters, including:

- Monitor workplace safety conditions and inspection results.
- Review safety reports, accidents, occupational diseases, and testing results.
- Recommend corrective and preventive measures to reduce workplace risks.
- Improve policies by proposing updates to the Risk Assessment Act and safety procedures.

Through these responsibilities, the Committee ensures continuous improvement of safety standards, effective communication between management and employees, and compliance with all legal and technical requirements.

Our analysis of workplace injuries shows that the most common incidents are commuting accidents, incidents related to working at heights, mechanical hazards when operating construction machinery and tools, and manual handling of loads, which can lead to sprains and strains. Slips and trips at worksites are also among the most frequent causes of injury.

During 2024, there were 3 reported injuries, 1 minor and 2 severe, with no fatalities, compared to 4 minor injuries in 2023. In 2025, there were 5 reported injuries, including 4 minor and 1 severe injury.

The total number of hours lost due to work-related injuries decreased from 1,624 in 2023 to 1,176 in 2024. However, in 2025 there was a slight increase in hours lost due to work-related injuries, amounting to 1,392 hours.

Figure 14 - Number of hours lost due to work-related injuries per year

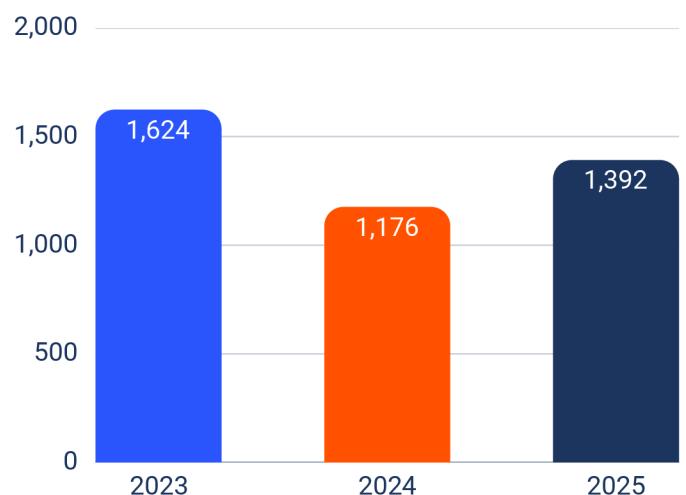

BUILDING A SAFER FUTURE

Employee Engagement, Diversity & Inclusion

We have adopted a Gender Equality Plan that defines concrete measures to ensure equal opportunities for women and men in all areas of work. The plan includes activities to prevent discrimination, support professional development, and promote balanced representation of genders across different organizational levels. As part of efforts to increase female representation in technical sectors, the Company will employ two early-career women under the age of 30 in junior site manager roles within Electrical and Civil Engineering. To strengthen female representation in leadership within traditionally male-dominated sectors such as Operations and Sales, we will develop a tailored leadership development and mentorship program for two emerging women leaders.

The total number of employees increased each year, reflecting a stable trend of business growth and the need for additional workforce. It rose from 359 in 2023 to 372 in 2024 and 394 in 2025. The number of women increased accordingly, from 82 in 2023 to 86 in 2024, and further, to 95 in 2025.

Figure 15 - Employee gender structure per year

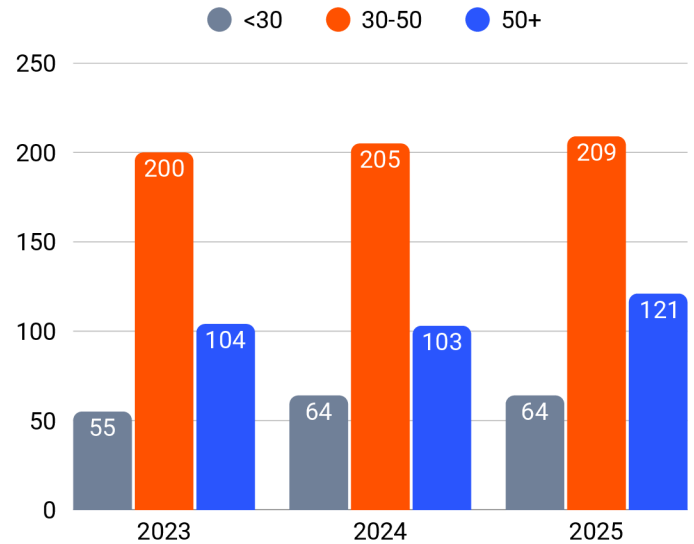
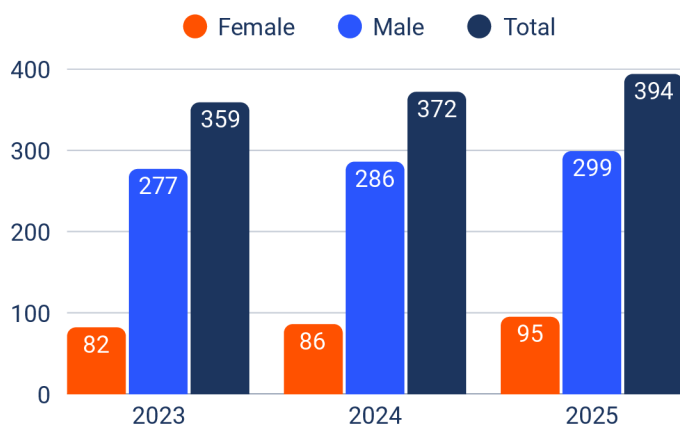

Figure 16 - Employee age structure per year

In 2025, the largest share of employees belonged to the 30–50 age group (209 employees), while the number of employees under the age of 30 amounted to 64, contributing to the stable rejuvenation of our workforce. The number of employees over 50 years of age amounted to 121, contributing to the preservation of experience and operational continuity.

The number of employees with permanent contracts increased from 311 to 331, while those with fixed-term contracts increased slightly from 61 to 63. We also employed two part-time employees in 2025.

We continue to prioritize stable employment, regularly increasing the number of permanent employees, from 24 in 2023, to 30 in 2024 and 25 in 2025.

BUILDING A SAFER FUTURE

Employee Engagement, Diversity & Inclusion

The age structure of management staff remained stable, with 8 employees aged between 30 and 50 years and 10 over 50 years of age in 2025. There were no employees under 30 years of age in management positions during the reporting period.

Figure 17 - Management age structure per year

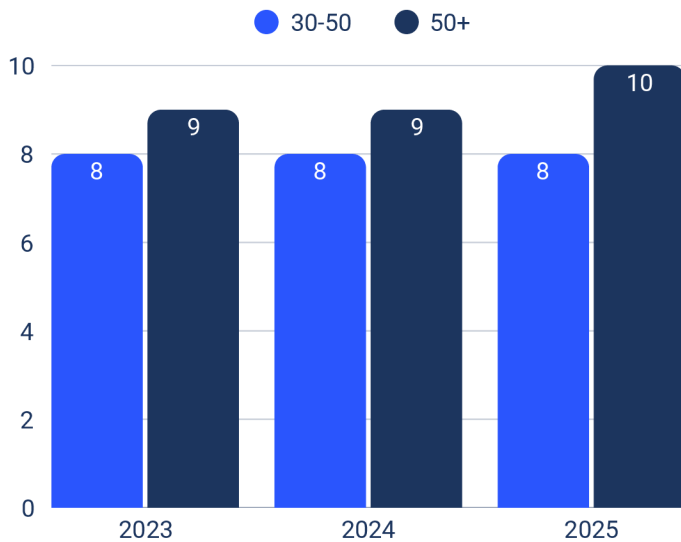

Women represent around 25% of the total workforce, 22% of management, and 33,3% of the Board of Directors. This distribution indicates that female representation in management and leadership positions is proportionate to, or exceeds, their overall share in the workforce.

Salaries and compensation are determined based on the Company's internal job classification system and are regularly benchmarked against market standards. All compensation practices are aligned with the Labor Law and the Company's internal Rulebook on Employment. The Company is committed to the principle of equal pay for equal work: employees with comparable qualifications, experience, skills, and levels of responsibility and contribution receive equal compensation, thereby maintaining a 0% gender pay gap. In addition, all female employees are entitled to fully paid maternity leave in accordance with applicable legislation.

The ratio between the highest and median salary in the company for 2025 is 5.28, indicating a relatively balanced internal pay structure and a moderate level of pay dispersion across the organization.

To improve access to preventive healthcare and support the overall wellbeing of our employees, we provide private health insurance for all staff. This contributes to improved employee satisfaction, reduced absenteeism, and a healthier, more resilient workforce.

Alongside this, we support employee growth through professional development programs, including language courses and soft skills training delivered in partnership with the AIM Institute, a consultancy specialized in business and employee development.

Figure 18 - Gender structure of management

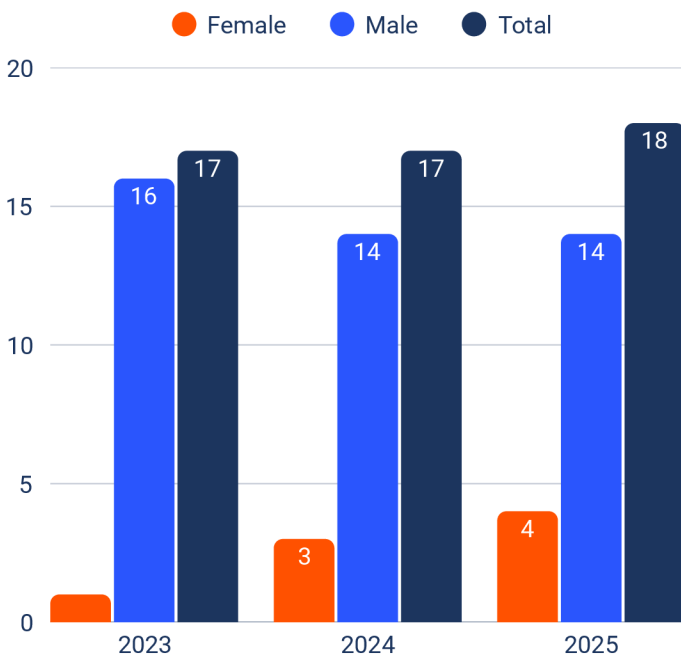

BUILDING A RESPONSIBLE FUTURE

Supply Chain Management

We evaluate our suppliers and subcontractors through a structured ESG questionnaire that covers key environmental, social, and governance topics. This assessment helps us identify how well our suppliers align with our standards on ethics, labor practices, and environmental responsibility.

Currently, the questionnaire applies to all material suppliers with an annual turnover exceeding EUR 100,000 as well as to subcontractors whose participation represents more than 10% of the total project value. The data collected is analyzed to identify suppliers with significant negative impacts based on ESG criteria.

To ensure compliance with ESG standards, we also developed a Supplier Code of Conduct. Starting in 2026, we will be integrating ESG clauses into all procurement contracts. We also introduced active monitoring and oversight of suppliers and subcontractors regarding the fulfillment of contractual obligations and key quality criteria of delivered goods and services.

In the next phase, we plan to define a supplier ranking system according to their level of compliance with our requirements and to establish exclusion criteria, which will become an integral part of our supplier selection and procurement process. The goal is for ESG data insights to be incorporated into 100% procurement decisions involving suppliers with annual procurement exceeding EUR 100,000 and subcontractors whose fees represent more than 10% of the project value.

Looking ahead, we will revise our supply and procurement policy to reflect ESG criteria based on the outcomes of the current supplier assessment.

The updated policy will include a structured decision-making process grounded in ESG factors, ensuring that procurement decisions are aligned with responsible and transparent practices. Through this approach, we are laying the foundation for systematic risk monitoring and strengthening accountability across our supply chain.

The current procurement policy applies to the entire company and is aligned with the ISO 9001:2015 standard, within the Integrated Management System. It covers all key stages of the process: creating purchase requests in the NAV system, collecting offers (from at least three suppliers where possible), selecting the most favorable offer through technical and commercial evaluation, contracting and document retention, implementation and monitoring of contract performance, verification of received goods and services, and procurement analysis.

The Director of Procurement is responsible for establishing, implementing, and maintaining this procedure, while the implementation is the responsibility of all employees involved in the process. Suppliers are evaluated, ranked, and periodically (at least once a year, or more frequently if required) re-evaluated based on criteria such as delivery reliability, certification, quality and timeliness of previous deliveries, price, and payment terms.

Records are maintained through standardized forms (Supplier Evaluation and Supplier List). Verification of purchased goods and services is conducted through inspections, measurements, and accompanying documentation, with external testing performed when necessary.

BUILDING A RESPONSIBLE FUTURE

Business Ethics

We view business ethics as the foundation of responsible and sustainable behavior. It guides our decisions, ensures integrity, transparency, and accountability, and helps us build trust with our stakeholders. By embedding ethical principles into our everyday operations, we strive to strengthen our long-term resilience and align our actions with our ESG values.

Organizational Structure

We have a clearly defined organizational structure in which all departments and units report directly to the General Director. This ensures a precise hierarchy and efficient coordination of business processes. Responsibilities are distributed vertically, from directors and managers to professional associates and operational staff.

Our governance structure is organized to ensure clear accountability, transparency, and effective decision-making across all operational levels. One-third of the members of the Management Board are executive directors, while the remaining members perform non-executive functions. Furthermore, the mandate of all board members is without a fixed term. Each business sector is headed by a designated director, responsible for managing day-to-day operations within their respective areas of competence.

Board members collectively possess a range of professional competencies relevant to our activities and their potential impacts, including financial management, strategic planning, operations, and compliance. Currently, stakeholders are not formally represented within the governing bodies.

Remuneration for members of the Management Board and executive directors is fixed and determined in accordance with internal corporate policies. Performance-based bonuses may be awarded once per year based on a decision, depending on the Company's overall business results. There are no individual KPI-linked incentives formally defined for executive directors. No contractual termination benefits or pension entitlements are defined.

Figure 19 - Organizational Structure of the Company



BUILDING A RESPONSIBLE FUTURE

Business Ethics - ESG Governance Structure

In 2024 we formed an ESG Team to ensure our company can address and manage the most important sustainability topics in an effective way. This was an important step in strengthening commitments to ESG and making sure these priorities are part of everyday decision-making.

The team is led by the CFO and focuses on developing and implementing our sustainability strategy, ensuring compliance with international standards, and preparing reports. Every member of the team is expected to take an active role in proposing measures, contributing ideas, and sharing information on time, so that together we can make progress and continuously improve in working toward our shared goals.

To ensure that all objectives remain up to date, the ESG team holds quarterly meetings where upcoming targets and progress achieved are reviewed. In addition, the team submits semi-annual and annual reports to the Board of Directors, ensuring that the company's leadership remains fully informed on all relevant ESG matters.

With the establishment of the ESG Team, we also created a clear structure that connects the Board of Directors, the ESG Team, and the ESG coordinator. The Board sets targets, approves or reviews reports, and provides direction at the highest level. This gives us a framework where strategic priorities are clearly set and translated into actions that can be measured and followed through.

The ESG team plays a key role in turning strategy into practice across departments. They make sure that daily activities are aligned with company goals and function as a bridge between management and operational teams. In this way, sustainability is embedded in the day-to-day activities.

Figure 20 - ESG team structure

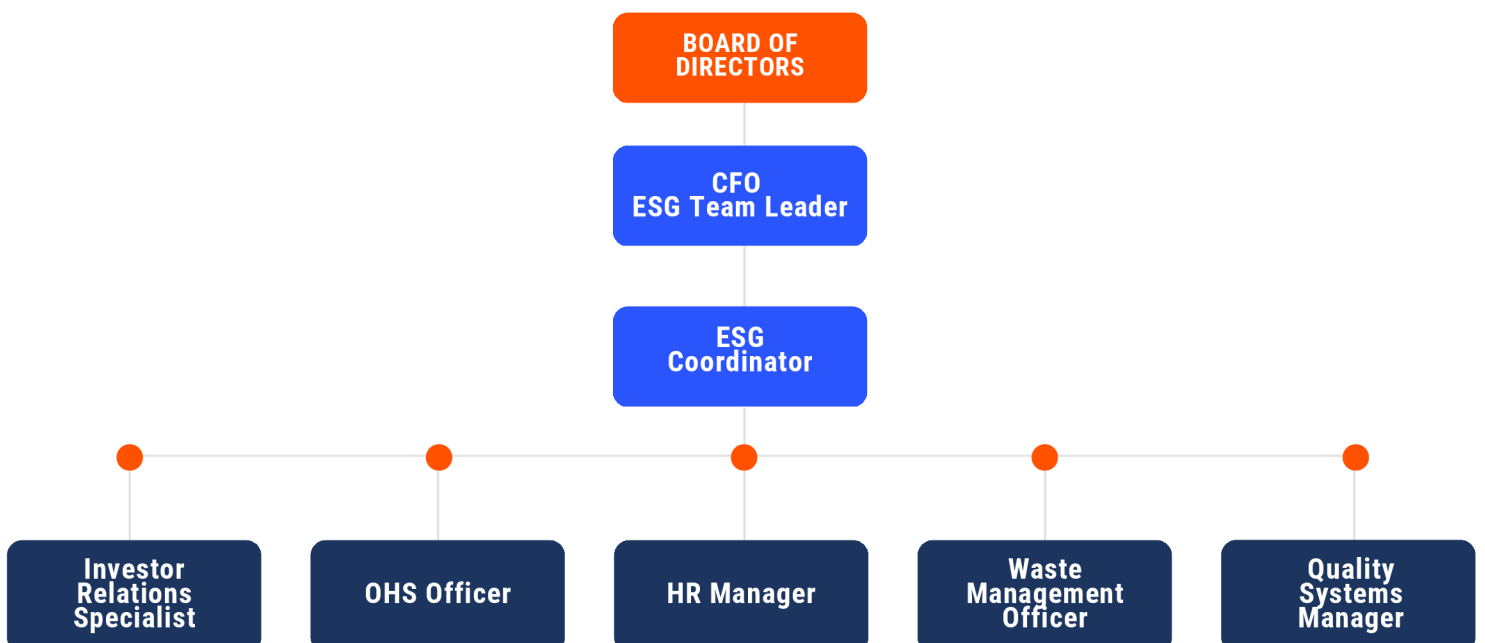

BUILDING A RESPONSIBLE FUTURE

Business Ethics - Conflict of Interest and Corruption

All our employees are required to follow our Code of Ethics, which ensures that all business activities are carried out in line with the highest business ethics standards. The Code clearly defines standards of behavior to prevent any form of discrimination or conflict of interest and provides clear procedures for reporting incidents or irregularities. We regularly monitor and report on instances of non-compliance within the organization, ensuring their timely and effective resolution. Additionally, all employees are bound by the Kodar Rulebook on the Prevention and Fight Against Corruption.

We encourage our employees to speak up whenever they observe potential misconduct, while ensuring full protection from any form of retaliation or adverse consequences among colleagues. Employees can report concerns related to internal whistleblowing either in written or oral form. Written reports may be submitted directly to us by ordinary or registered mail, or electronically, in accordance with applicable law and available technical means. Oral reports are documented through official statements, with minutes taken at the time of submission. This process is determined through the Rulebook on the Internal Whistleblowing Procedure.

We have clearly defined procedures outlining our obligations and the steps to be taken in response to a reported incident. We are committed to responding promptly, no later than 15 days after receiving a report, and to taking all necessary measures to protect the employees who raise concerns.

Once the process is completed, the employee is informed of the outcome. During the fiscal years 2023, 2024 and 2025, no incidents related to conflicts of interest were recorded.

During the risk assessment process no significant corruption-related risks were identified. Moreover, we were not involved in any legal proceedings concerning corruption during the fiscal years 2023, 2024 and 2025, and no confirmed incidents of corruption were recorded in this period.

All business partners (100%) have been introduced to the Company's anti-corruption policies and procedures. In addition, the majority of contracts include a mutual clause on anti-corruption commitments and the implementation of a whistleblowing mechanism. Annual anti-corruption training is provided to senior management to strengthen awareness and ensure consistent application of ethical business practices. The sessions include departmental risk assessments, followed by measures to mitigate risks and enhance the company's resilience to corruption.

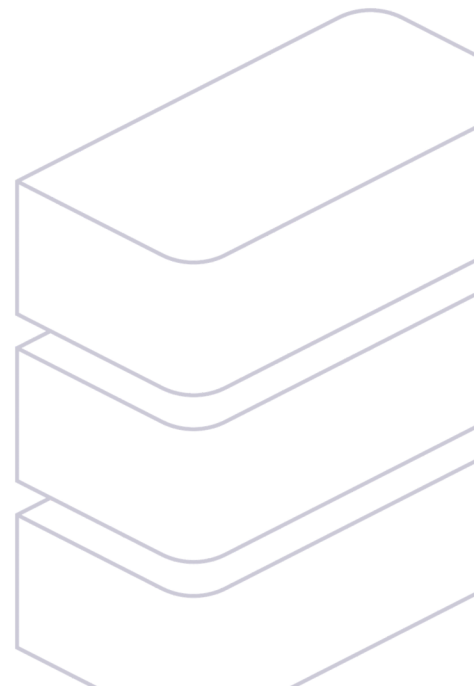

BUILDING A RESPONSIBLE FUTURE

Risk management

Managing critical risks is an important part of our project planning and decision-making processes. Given the complexity of EPC activities in the energy and infrastructure sectors, identifying and assessing potential risks at an early stage is a key element of project feasibility and anticipating potential social and environmental impacts.

For every new project where we act as an investor, we conduct a detailed risk assessment through an **Environmental and Social Impact Assessment (ESIA)** in line with national legislation, international best practices and our internal **Risk Management Policy**. Through the ESIA, we systematically identify and evaluate potential environmental and social risks and impacts.

Based on the results, we identify key risks and integrate them into the investment decision-making process. The Board of Directors reviews the outcomes of each assessment when considering new investments. Depending on the identified risks, the Board determines whether a project will proceed and defines the specific environmental and social risk management measures to be applied during its implementation.

To ensure a consistent and systematic approach, we have established a formal procedure for environmental and social risk assessment for new projects and operations. This procedure sets out a structured framework for identifying, evaluating, and managing environmental and social risks and impacts. It ensures that potential risks are recognized and addressed through clearly defined action plans, prioritization, and continuous monitoring.

The procedure applies to all activities and projects implemented within the Kodar Group, regardless of their location or scale.

Thereafter, we develop **Environmental and Social Management Programs** that set clear goals and practical actions for addressing identified risks. High-level risks are prioritized and managed with additional resources, stricter deadlines, and closer oversight, while medium and low-level risks are handled according to their relevance and potential impact. Responsibilities, timelines, and performance indicators are clearly defined to ensure consistent and accountable risk management across all projects.

To ensure that all mitigation measures are implemented effectively, we have introduced a monitoring and reporting system. This includes regular tracking of performance indicators, verifying implementation progress, and notifying relevant authorities in case of any deviations or difficulties. Monitoring activities are conducted at defined intervals, and the findings are used to evaluate the effectiveness of actions and update plans when necessary.

By applying this procedure across all our projects, we ensure compliance with legal requirements, international standards, and best industry practices. This structured and proactive approach enables us to manage environmental and social risks responsibly and ensure the long-term sustainability of our business activities.

29

GRI INDEX

Material topics	Reference	GRI reporting	Report Section	Page
General Disclosures	GRI 2: General Disclosures 2021 Disclosure 2-1	Organizational details	About the company	4
	GRI 2: General Disclosures 2021 Disclosure 2-2	Entities included in the sustainability (non-financial) report	Introducing our 2025 Sustainability report	3
	GRI 2: General Disclosures 2021 Disclosure 2-3	Reporting period, frequency, and contact point	Introduction	3
	GRI: General Disclosures 2021 Disclosure 2-4	Restatements of information	Not applicable	
	GRI: General Disclosures 2021 Disclosure 2-5	External assurance	Not applicable	
Activities and Workers	GRI 2: General Disclosures 2021 Disclosure 2-6	Activities, value chain, and other business relationships	About the company; Supply chain management	4; 24
	GRI 2: General Disclosures 2021 Disclosure 2-7	Employees	Employee engagement, diversity and inclusion	22-23
	GRI 2: General Disclosures 2021 Disclosure 2-8	Workers who are not employees	Not applicable	

30

GRI INDEX

Material topics	Reference	GRI reporting	Report Section	Page
Governance	GRI 2: General Disclosures 2021 Disclosure 2-9	Governance structure and composition	Organizational structure	25
	GRI 2: General Disclosures 2021 Disclosure 2-10	Nomination and selection of the highest governance body	Not applicable	
	GRI 2: General Disclosures 2021 Disclosure 2-11	Chair of the highest governance body	Organizational structure	25
	GRI 2: General Disclosures 2021 Disclosure 2-12	Role of the highest governance body in overseeing the management of impacts	Not applicable	
	GRI 2: General Disclosures 2021 Disclosure 2-13	Delegation of responsibility for managing impacts	Not applicable	
	GRI 2: General Disclosures 2021 Disclosure 2-14	Role of the highest governance body in sustainability reporting	ESG Governance structure	26
	GRI 2: General Disclosures 2021 Disclosure 2-15	Conflicts of interest	Conflict of interest and corruption	27
	GRI 2: General Disclosures 2021 Disclosure 2-16	Communication of critical concerns	Risk Management	28
	GRI 2: General Disclosures 2021 Disclosure 2-17	Collective knowledge of the highest governance body	ESG Governance structure	26
	GRI 2: General Disclosures 2021 Disclosure 2-18	Evaluation of the performance of the highest governance body	Organizational structure	25
	GRI 2: General Disclosures 2021 Disclosure 2-19	Remuneration policies	Organizational structure	25
	GRI 2: General Disclosures 2021 Disclosure 2-20	Process to determine remuneration	Organizational structure	25
	GRI 2: General Disclosures 2021 Disclosure 2-21	Annual total compensation ratio	Employee Engagement, Diversity & Inclusion	23

31

GRI INDEX

Material topics	Reference	GRI reporting	Report Section	Page
Strategy, Policies, and Practices	GRI 2: General Disclosures 2021 Disclosure 2-22	Statement on Sustainable Development Strategy	Not applicable	
	GRI 2: General Disclosures 2021 Disclosure 2-23	Policies and commitments	Not applicable	
	GRI 2: General Disclosures 2021 Disclosure 2-24	Integration of policies and commitments into business operations	Not applicable	
	GRI 2: General Disclosures 2021 Disclosure 2-25	Processes for addressing negative impacts	Risk Management	28
	GRI 2: General Disclosures 2021 Disclosure 2-26	Mechanisms for seeking advice and raising concerns	Conflict of interest and corruption	27
	GRI 2: General Disclosures 2021 Disclosure 2-27	Compliance with laws and regulations	Not applicable	
	GRI 2: General Disclosures 2021 Disclosure 2-28	Membership in associations	Not applicable	
Stakeholder Engagement	GRI 2: General Disclosures 2021 Disclosure 2-29	Approach to stakeholder engagement	Human rights and community relations	17-18
	GRI 2: General Disclosures 2021 Disclosure 2-30	Collective agreements	Not applicable	
Material topics	GRI 3-1	Process of determining material topics	Materiality	8-9
	GRI 3-2	List of material topics	Materiality	8-9
	GRI 3-3	Management of material topics	Materiality	8-9

32

GRI INDEX

Material topics	Reference	GRI reporting	Report Section	Page
Supplier Environmental Assessment	GRI 308-1	New suppliers evaluated using environmental criteria	Supply chain management	24
	GRI 308-2	Negative environmental impacts in the supply chain and actions taken	<p>In 2026, we began distribution of supplier questionnaires for all material suppliers with annual turnover above EUR 100,000, as well as subcontractors representing over 10% of total project value. The collected data will be analyzed to identify suppliers with significant negative impacts. In the next phase, we plan to define a ranking methodology and minimum exclusion criteria.</p>	
	GRI 414-1	New suppliers evaluated using social criteria		
	GRI 414-2	Negative social impacts in the supply chain and actions taken		
Waste	GRI 306-1	Waste generation and significant impacts related to waste		Waste and hazardous materials management
	GRI 306-2	Management of significant waste-related impacts	Waste and hazardous materials management	13-14
	GRI 306-3	Waste generated	Waste and hazardous materials management	13-14
	GRI 306-4	Waste diverted from disposal	Waste and hazardous materials management	13-14
	GRI 306-5	Waste directed to disposal	Waste and hazardous materials management	13-14
Emissions	GRI 305-1	Direct (Scope 1) GHG emissions	GHG emissions	10
	GRI 305-2	Indirect (Scope 2) GHG emissions from energy use	GHG emissions	10
	GRI 305-3	Other indirect (Scope 3) GHG emissions	Not applicable	
	GRI 305-4	GHG emissions intensity	Not applicable	
	GRI 305-5	Reduction of GHG emissions	GHG emissions	10
	GRI 305-6	Emissions of ozone-depleting substances (ODS)emissions	Not applicable	
	GRI 305-7	Nitrogen oxides (NOx), sulfur oxides (SOx), and other air emissions	Not applicable	

33

GRI INDEX

Material topics	Reference	GRI reporting	Report Section	Page
Energy	GRI 302-1	Energy consumption within the organization	Energy management	12
	GRI 302-2	Energy consumption outside the organization	Not applicable	
	GRI 302-3	Energy intensity	Not applicable	
	GRI 302-4	Reduction of energy consumption	Energy consumption	12
	GRI 302-5	Reduction of energy requirements of products and services	Not applicable	
Inclusion and diversity	GRI 401-1	New employee hires and employee turnover	Employee engagement, diversity and inclusion	22-23
	GRI 401-2	Benefits provided to full-time employees	Employee engagement, diversity and inclusion	22-23
	GRI 401-3	Maternity leave	Employee engagement, diversity and inclusion	22-23
	GRI 405-1	Diversity of governance bodies and employees	Employee engagement, diversity and inclusion	22-23
	GRI 405-2	Ratio of basic salary and remuneration of women to men	Employee engagement, diversity and inclusion	22-23

34

GRI INDEX

Material topics	Reference	GRI reporting	Report Section	Page
Health and Safety	GRI 403-1	Occupational Health and Safety Management System	Employee health and safety	19-21
	GRI 403-2	Identification of Hazards, Risk Assessment, and Incident Investigation	Employee health and safety	19-21
	GRI 403-3	Occupational Health Services	Employee health and safety	19-21
	GRI 403-4	Employee Participation, Consultation, and Communication on Health and Safety	Not applicable	
	GRI 403-5	Employee Training on Occupational Health and Safety	Employee health and safety	19-21
	GRI 403-6	Promotion of Employee Health	Employee Engagement, Diversity & Inclusion	23
	GRI 403-7	Prevention and Mitigation of Health and Safety Impacts Related to Business Activities	Employee health and safety	19-21
	GRI 403-8	Employees Covered by the Occupational Health and Safety Management System	Not applicable	
	GRI 403-9	Work-Related Injuries	Employee health and safety	19-21
	GRI 403-10	Work-Related Health Issues	Not applicable	
Community wellbeing	GRI 413-1	Operations with local community engagement, impact assessment, and development programs	Human rights and community relationships	17-18
	GRI 413-2	Operations with significant actual and potential negative impacts on local communities	Not applicable	

35

GRI INDEX

Material topics	Reference	GRI reporting	Report Section	Page
Ecological impact	GRI 304-1	Operational sites owned, leased, managed in, or adjacent to, protected areas and areas of high biodiversity value outside protected areas	Ecological impact	15-16
	GRI 304-2	Significant impacts of activities, products, and services on biodiversity	Ecological impact	15-16
	GRI 304-3	Habitats protected or restored	Ecological impact	15-16
	GRI 304-4	IUCN Red List species and national conservation list species with habitats in areas affected by operations	Not applicable	
Business ethics	GRI 205-1	Assessment of operations for risks related to corruption	Conflict of interest and corruption	27
	GRI 205-2	Communication and training about anti-corruption policies and procedures	Conflict of interest and corruption	27
	GRI 205-3	Confirmed incidents of corruption and actions taken	No recorded cases	